

Zubehör/Ersatzteile

Accessories/Spare parts

Accessoires/Pièces de rechange



A

Kühlmittelübergabesätze

Coolant adaptor sets

Jeux d'adaptateurs pour arrosage

für HSK-Größe for HSK size pour taille HSK	Gewinde Thread Filetage G	d	d ₁	l ₁	l ₂	Bestell-Nummer Order Number No de cde.
32	M 10 x 1,0	6	3,5	5,5	25,7	262 002
40	M 12 x 1,0	8	5,0	7,5	29,2	262 003
50	M 16 x 1,0	10	6,4	9,5	32,7	262 004
63	M 18 x 1,0	12	8,0	11,5	36,2	262 005
80	M 20 x 1,5	14	10,0	13,5	40,0	262 006
100	M 24 x 1,5	16	12,0	15,5	43,6	262 007

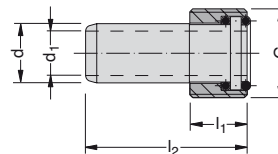

Kegelgewindestifte für die MVS-Verbindungsstelle

Taper thread pins for the MVS connection

Tige filetée pour la conique connexion MVS

MVS-Verbindungsstelle MVS connection Connexion MVS	Gewinde Thread Filetage G	Schlüsselweite Key size Dim. de la clé	Bestell-Nummer Order Number No de cde.
d ₄ d ₃			
50 - 28	M 12 x 1,0	16,7	132 145
63 - 36	M 16 x 1,5	19,8	132 146
80 - 36	M 16 x 1,5	28,0	132 191
100 - 56	M 24 x 2,0	34,0	215 470

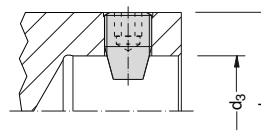

Befestigungsteile für die MVS- und D 60-Verbindungsstelle

Clamping pieces for the MVS and D 60 connection

Éléments de fixation pour la connexion MVS et D 60

MVS-Verbindungsstelle MVS connection Connexion MVS	Bezeichnung Code Désignation	Schlüsselweite Key size Dim. de la clé	Bestell-Nummer Order Number No de cde.
d ₄ d ₃ <td></td> <td>d x l</td> <td></td>		d x l	
100 - 56	Mitnehmerstein ① Torque bush Tenon d'entraînement		115 641
100 - 56	Zylinderschraube ② Cap screw Vis à tête cylindrique	5	M 6 x 16 115 147
D 60	Mitnehmerstein ① Torque bush Tenon d'entraînement		115 643 (125 mm) KW 31562 (110 mm)
D 60	Zylinderschraube ② Cap screw Vis à tête cylindrique	10	M 12 x 25 115 237
D 60	Zylinderschraube ③ Cap screw Vis à tête cylindrique	14	M 16 x 80 115 170 ^{a)}
D 60	Zylinderschraube ③ Cap screw Vis à tête cylindrique	14	M 16 x 55 215 189 ^{b)}

^{a)} zur Befestigung von Ausdrehwerkzeugen ab Ø 200 mm, siehe Kapitel D und E

^{b)} zur Befestigung von Messerköpfen nach DIN 1830

^{a)} for mounting boring tools from 200 mm diameter upwards, please see section D and E

^{b)} for mounting cutter heads to DIN 1830

MVS 100-56

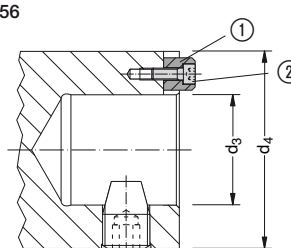

Aufnahmedorn D 60

Holding arbor D 60
Mandrin D 60

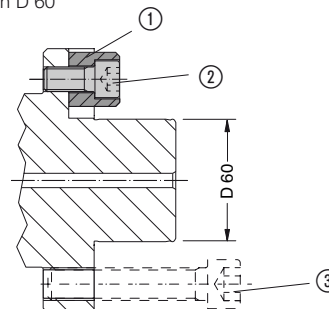

^{a)} pour fixation d'outils à partir d'un diamètre de 200 mm, voir les chapitres D et E

^{b)} pour fixation de fraises suivant DIN 1830

Zubehör Spannzangenfutter 8° ER 40

Accessories collet chucks 8° ER 40

Accessoires mandrins porte pinces 8° ER 40

Einteilige Spannmutter

One-piece clamping nut

Écrou de serrage d'une pièce

Nenngröße Nominal size Dimension nominale	l_1	d_1	Bestell-Nummer Order Number No de cde.
ER 40	25,5	63	215 926

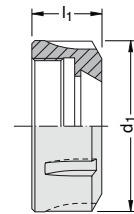

A

Einteilige Spannmutter, vorgefertigt zur Aufnahme von Dichtscheiben

One-piece clamping nut, for use with sealing discs

Écrou de serrage d'une pièce pré-disposé, pour l'usage de disques d'étanchéité

Nenngröße Nominal size Dimension nominale	l_1	d_1	Bestell-Nummer Order Number No de cde.
ER 40	34	63	278 001

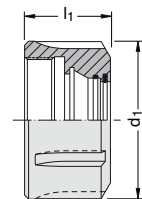

Spannzangen DIN 6499-B 8°

Collets DIN 6499-B 8°

Pinces DIN 6499-B 8°

Spannbereich A Clamping range A Capacité de serrage A	l_1	d_1	Bestell-Nummer Order Number No de cde.
15,0 - 14,0	46	40	071 790
18,0 - 17,0	46	40	071 793
20,0 - 19,0	46	40	071 795
23,0 - 22,0	46	40	071 798

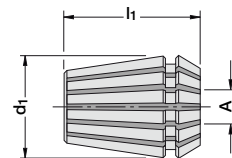

Dichtscheiben

Sealing discs

Disques d'étanchéité

Spannbereich A Clamping range A Capacité de serrage A	Bestell-Nummer Order Number No de cde.
15,0 - 14,5	278 029
18,0 - 17,5	278 035
20,0 - 19,5	278 039
23,0 - 22,5	278 045

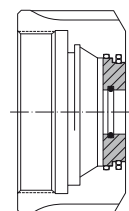

Weitere Ausführungen siehe Kapitel G.

Further types, see chapter G.

Pour d'autres exécutions, voir chapitre G.

Anwendung von Spannmuttern mit Dichtscheiben bei zentraler Kühlschmierstoffzufuhr

Application of clamping nuts with sealing discs, when using central coolant feed

Application d'écrous de serrage avec de disques d'étanchéité en cas d'arrosage central

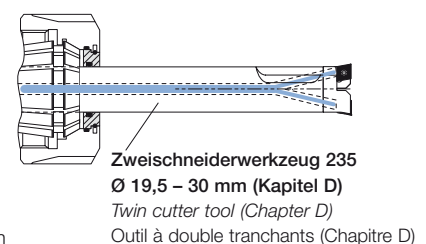
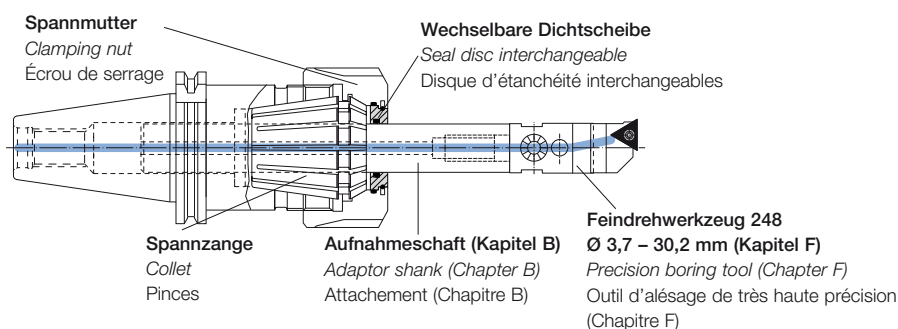

Zubehör/Ersatzteile

Accessories/Spare parts

Accessoires/Pièces de rechange

Bedienungsschlüssel

Service keys

Clés de service

A

für HSK-Größe for HSK size pour taille HSK	d	Bestell-Nummer Order Number No de cde.
32	8,5	315 234
40	10,5	315 235
50	14,5	215 726
63	16,5	215 727*
80	18,0	415 127
100	22,0	215 728

* zweiteilige Ausführung · two-piece execution · mise en oeuvre en deux pièces

Nenngröße Nominal size Dimension nominale	d	Bestell-Nummer Order Number No de cde.
ER 40	63	215 931

Schlüsselweite Key size Dim. de la clé	Ausführung Type Modèle	Bestell-Nummer Order Number No de cde.
5	B	115 577
6	B	115 578
8	B	115 579
10	B	115 580
12	D	215 638
14	C	215 639

Für das gesamte **WHL**-Werkzeugprogramm kann ein kompletter Schlüsselsatz bestellt werden.

A complete set of wrenches can be ordered for the entire **WHL** tool range.

Ausführung U (für Kühlmittelübergabesatz)

Type U (for coolant adaptor set)

Modèle U (pour jeux d'adaptateurs pour arrosage)

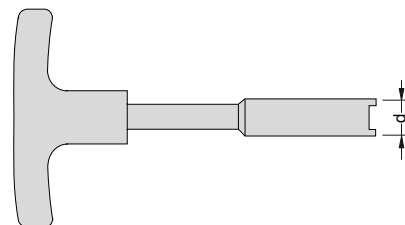

Ausführung T

Type T

Modèle T

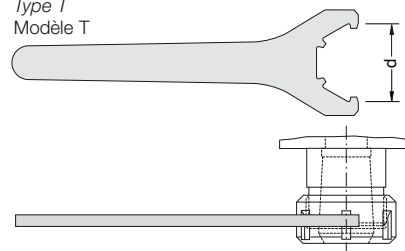

Ausführung B

Type B

Modèle B

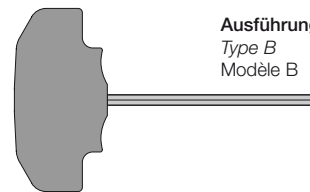

Ausführung C

Type C

Modèle C

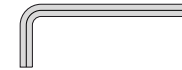

Ausführung D

Type D

Modèle D

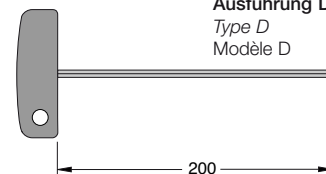

Un jeu complet de clés est disponible pour l'ensemble du programme d'outils **WHL**.

Schlüsselsatz Service keys Set de clés	Bestell-Nummer Order Number No de cde.
	103 025

bestehend aus 25 Bedienungsschlüsseln:

consisting of 25 service keys:

comprenant de 25 clés de service :

Ausführung / Type / Modèle

A

B

C

F

H

K

P

Größe / Size / Dim.

s 1,5 / s 2 / s 2,5 / s 3 / s 4

s 4 / s 5 / s 6 / s 8 / s 10 / s 12 / s 14

s 7

s 4

T 6 / T 7 / T 8 / T 10 / T 15 / T 20 / T 25

0,5 x 3

s 13 / s 15 / s 19

Zubehör/Ersatzteile

Accessories/Spare parts

Accessoires/Pièces de rechange

Anzugsbolzen

Pull studs

Steilkegelgröße Taper size Dim. du cône	d_1	d_2	d_3	d_4	l_1	l_2	Bestell-Nummer Order Number No de cde.
40	M 16	17	7,0	19	54	26	KW 15 004
45	M 20	21	9,5	23	65	30	KW 15 386
50	M 24	25	11,5	28	74	34	KW 14 483

Steilkegelgröße Taper size Dim. du cône	d_1	d_2	d_3	d_4	l_1	l_2	Bestell-Nummer Order Number No de cde.
40	M 16	17	7,0	19	54	26	K 17 044
45	M 20	21	9,5	23	65	30	K 17 046
50	M 24	25	11,5	28	74	34	K 17 048

Anzugsbolzen mit Einstich zum Einziehen für den Umbau von Spannzeugen nach DIN 69 871 zu Spannzeugen entsprechend DIN 2080.

Pull studs with clamping groove for conversion of clamping elements to DIN 69 871 into clamping elements according to DIN 2080.

Steilkegelgröße Taper size Dim. du cône	d_1	d_2	d_3	l_1	l_2	l_3	Bestell-Nummer Order Number No de cde.
40	M 16	17	M 16	53,1	25,1	19	KW 16 185^{a)}
50	M 24	25	M 24	65,1	25,1	18	KW 15 607^{b)}

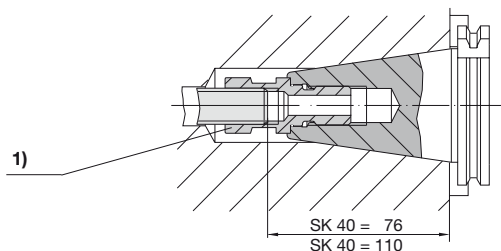

¹⁾ Bei Verwendung der Anzugsbolzen KW 16 185 und KW 15 607 sind die Mitnehmersteine entsprechend anzupassen, die Maße 76 mm bzw. 110 mm zu prüfen und die Anzugsstange evtl. zu kürzen.



¹⁾ When using KW 16 185 and KW 15 607 pull studs, the driver pins must be adapted accordingly, the 76 mm and 110 mm dimensions checked and the drawbar shortened if necessary.



Tirettes

DIN 69 872-A

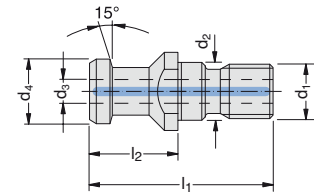

A

DIN 69 872-B

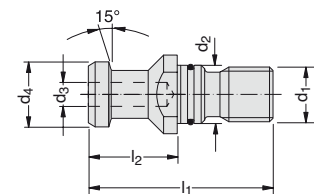

Tirettes avec rainure de serrage pour la transformation du serrage selon norme DIN 69 871 en serrage selon norme DIN 2080.

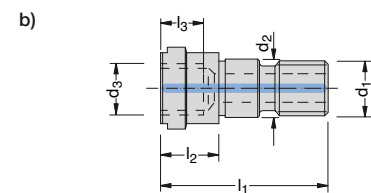
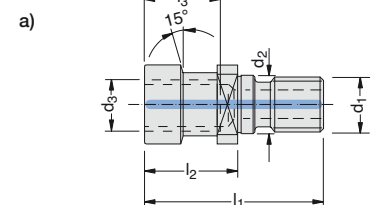

¹⁾ En cas d'utilisation des tirettes KW 16 185 et KW 15 607, adapter les tenons, vérifier les dimensions 76 mm et 110 mm et raccourcir éventuellement la barre de traction.



Zubehör/Ersatzteile

Accessories/Spare parts

Accessoires/Pièces de rechange



A

Anzugsbolzen

Pull studs

Tirettes

Steilkegelgröße Taper size Dim. du cône	d_1	d_2	d_3	d_4	l_1	l_2	Bestell-Nummer Order Number No de cde.
40	M 16	17	7,5	18,95	44,5	16,40	KW 15 790 DMG
50	M 24	25	11,5	29,10	65,5	25,55	KW 15 606

ISO 7388

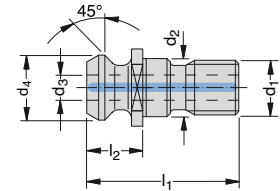

Steilkegelgröße Taper size Dim. du cône	d_1	d_2	d_3	d_4	l_1	l_2	Bestell-Nummer Order Number No de cde.
40	M 16	-	7,50	18,95	38,0	16,40	KW 17 332
45	M 20	-	9,25	24,05	48,0	20,95	KW 17 333
50	M 24	-	11,50	29,10	58,5	25,55	KW 11 757

ANSI

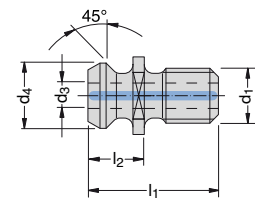

Steilkegelgröße Taper size Dim. du cône	d_1	d_2	d_3	d_4	l_1	l_2	Bestell-Nummer Order Number No de cde.
BT 40	M 16	17	10	15	60	35	KW 15 389
BT 50	M 24	25	17	23	85	45	KW 15 353

MAS-BT

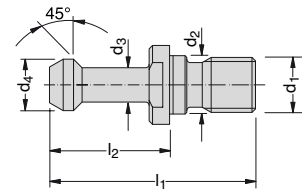

Steilkegelgröße Taper size Dim. du cône	d_1	d_2	d_3	d_4	l_1	l_2	Bestell-Nummer Order Number No de cde.
BT 40	M 16	17	10	15	60	35	KW 15 390
BT 50	M 24	25	17	23	85	45	KW 15 392

MAS-BT

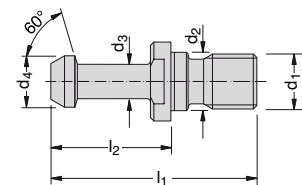

Steilkegelgröße Taper size Dim. du cône	d_1	d_2	d_3	d_4	l_1	l_2	Bestell-Nummer Order Number No de cde.
BT 40	M 16	17	10	15	60	35	KW 22 154
BT 50	M 24	25	17	23	85	45	KW 14 652

MAS-BT

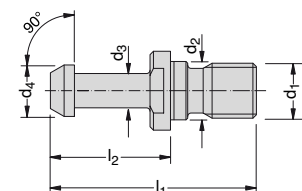

Zubehör/Ersatzteile

Accessories/Spare parts

Accessoires/Pièces de rechange

Anzugsbolzen

Pull studs

Tirettes



A

Steilkegelgröße Taper size							Bestell-Nummer Order Number
Dim. du cône	d ₁	d ₂	d ₃	d ₄	l ₁	l ₂	No de cde.
BT 40	M 16	17	10	15	60	35	KW 24 299
BT 50	M 24	25	17	23	85	45	KW 24 300

MAS-BT mit Durchgangsbohrung
with throughhole
avec trou de passage

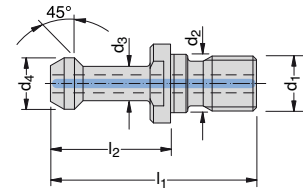

Steilkegelgröße Taper size							Bestell-Nummer Order Number
Dim. du cône	d ₁	d ₂	d ₃	d ₄	l ₁	l ₂	No de cde.
BT 40	M 16	17	10	15	60	35	KW 24 301
BT 50	M 24	25	17	23	85	45	KW 24 302

MAS-BT mit Durchgangsbohrung
with throughhole
avec trou de passage

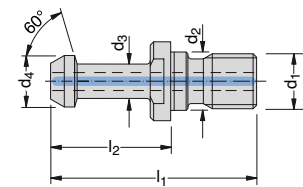

Steilkegelgröße Taper size							Bestell-Nummer Order Number
Dim. du cône	d ₁	d ₂	d ₃	d ₄	l ₁	l ₂	No de cde.
BT 40	M 16	17	10	15	60	35	KW 24 303
BT 50	M 24	25	17	23	85	45	KW 24 304

MAS-BT mit Durchgangsbohrung
with throughhole
avec trou de passage

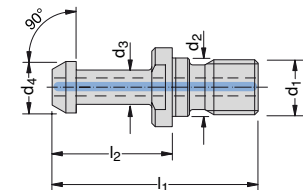

Zubehör/Ersatzteile

Accessories/Spare parts

Accessoires/Pièces de rechange



A

Montagehalter komplett

Mounting fixture complete

Dispositif complet d'assemblage



Kegelgröße <i>Taper size</i> Dim. du cône	Ausführung <i>Type</i> Modèle	Bestell-Nummer <i>Order Number</i> No de cde.
30	DIN 69 871 / ANSI / CAT	098 030
40	DIN 69 871 / ANSI / CAT	098 009
45	DIN 69 871 / ANSI / CAT	098 010
50	DIN 69 871 / ANSI / CAT	098 014
40	DIN 2080	098 007
50	DIN 2080	098 013
BT 40	MAS-BT	098 011
BT 45	MAS-BT	098 012
BT 50	MAS-BT	098 015
40	HSK-A	098 051
50	HSK-A	098 052
63	HSK-A	098 053
80	HSK-A	098 054
100	HSK-A	098 055

Zubehör/Ersatzteile

Accessories/Spare parts

Accessoires/Pièces de rechange

Montagehalter

Mounting fixture

Dispositif de montage-démontage



A

Adapter
Adaptor
Adaptateur

Basiskörper
Basic body
Corps de base



Zentraler Freigabeknopf zum Schwenken der Aufnahme in die Rüstposition

Central release button to swivel the receptacle into the set-up position

Bouton central d'acquiescement pour mise en position de montage de l'attachement

Bezeichnung Code Désignation	Ausführung Type Modèle	Bestell-Nummer Order Number No de cde.
Basiskörper / Basic body / Corps de base		098 060
Adapter / Adaptor / Adaptateur	SK 40	098 061
Adapter / Adaptor / Adaptateur	SK 50	098 062
Adapter / Adaptor / Adaptateur	HSK-A 032	098 063
Adapter / Adaptor / Adaptateur	HSK-A 040	098 064
Adapter / Adaptor / Adaptateur	HSK-A 050	098 065
Adapter / Adaptor / Adaptateur	HSK-A 063	098 066
Adapter / Adaptor / Adaptateur	HSK-A 080	098 067
Adapter / Adaptor / Adaptateur	HSK-A 100	098 068
Adapter / Adaptor / Adaptateur	C 5 (Capto)	098 069
Adapter / Adaptor / Adaptateur	C 6 (Capto)	098 070
Adapter / Adaptor / Adaptateur	C 8 (Capto)	098 071